

MAX2982

Industrial Broadband Powerline Modem

General Description

The MAX2982 powerline transceiver utilizes state-of-the-art CMOS design techniques to deliver the highest level of performance, flexibility, and operational temperature range at reduced cost. This highly integrated design combines the media access control (MAC) and the physical (PHY) layers in a single device. The MAX2982 digital baseband and its companion device, the MAX2981 analog front-end (AFE) with integrated line driver, offer a complete high-speed powerline communication solution fully compliant with HomePlug® 1.0 Powerline Alliance Specification.

The MAX2982 offers reliable broadband communication for industrial environments. The PHY layer comprises an 84-carrier OFDM modulation engine and forward error correcting (FEC) blocks. The OFDM engine can modulate the signals in one of four modes of operation: DBPSK, DQPSK (1/2 rate FEC), DQPSK (3/4 rate FEC), and ROBO. The MAX2982 offers -1dB SNR performance in ROBO mode, a robust mode of operation, to maintain communication over harsh industrial line conditions. Additionally, advanced narrow-band interference rejection circuitry provides immunity from jammer signals.

The MAX2982 offers extensive flexibility by integrating an ARM946E-S™ microprocessor allowing feature enhancement, worldwide regulatory compliance, and improved testability. Optional spectral shaping and notching profiles provide an unparalleled level of flexibility in system design. Additionally, the automatic channel adaptation and interference rejection features of the MAX2982 guarantee outstanding performance. Privacy is provided by a hard-macro DES encryption with key management.

The MAX2982 supports an IEEE® 802.3 standard *Media Independent Interface* (MII), *Reduced Media Independent Interface* (RMII), synchronous FIFO supporting a glue-free interface to microcontrollers, USB1.1, and 10/100 Ethernet MAC. These interfaces and standards compliance simplify configuration of monitoring and control networks. Fast response time and an integrated temperature sensor make the MAX2982 an excellent solution for real-time control over power lines. The MAX2982 operates over the -40°C to +105°C temperature range and is available in a 128-pin, lead-free, LQFP package.

HomePlug is a registered trademark of HomePlug Powerline Alliance, Inc.

ARM946E-S is a trademark of ARM Limited.

IEEE is a registered service mark of the Institute of Electrical and Electronics Engineers, Inc.

For pricing, delivery, and ordering information, please contact Maxim Direct at 1-888-629-4642, or visit Maxim's website at www.maximintegrated.com.

Features

- ◆ **Single-Chip Powerline Networking Transceiver**
- ◆ **HomePlug 1.0 Compliant**
- ◆ **-40°C to +105°C Operating Temperature Range**
- ◆ **Integrated Temperature Sensor**
- ◆ **Up to 14Mbps Data Rate**
- ◆ **Low-Rate Adaptation (LORA) Operation Option Provides -2dB SNR Performance at 500kbps**
- ◆ **4.49MHz to 20.7MHz Frequency Band**
- ◆ **Flexible MAC/PHY**
 - ◇ **Field Upgradable Firmware Using TFTP**
 - ◇ **Spectral Shaping Including Bandwidth and Notching Capability**
 - ◇ **Programmable Preamble**
 - ◇ **128kB Internal SRAM**
- ◆ **Advanced Narrowband Interference Rejection Circuitry**
- ◆ **84-Carrier, OFDM-Based PHY**
 - ◇ **Automatic Channel Adaptation**
 - ◇ **FEC (Forward Error Correction)**
 - ◇ **DQPSK, DBPSK Modulation**
 - ◇ **Enhanced ROBO Mode with -1dB SNR**
- ◆ **Large Bridge Table: Up to 512 Addresses**
- ◆ **56-Bit DES Encryption with Key Management for Secure Communication**
- ◆ **On-Chip Communication Interfaces**
 - ◇ **UART**
 - ◇ **10/100 Ethernet**
 - ◇ **MII/RMII**
 - ◇ **USB1.1**
 - ◇ **High-Speed Synchronous FIFO**
- ◆ **AEC-Q100-REV-G Automotive Grade Qualification**

Applications

Industrial Automation
Motor Control
Remote Monitoring and Control
Building Automation
Broadband Over Shared Coax/Copper Line

Ordering Information appears at end of data sheet.

For related parts and recommended products to use with this part, refer to www.maxim-ic.com/MAX2982.related.

ABRIDGED

MAX2982 Industrial Broadband Powerline Modem

Typical Application Circuit

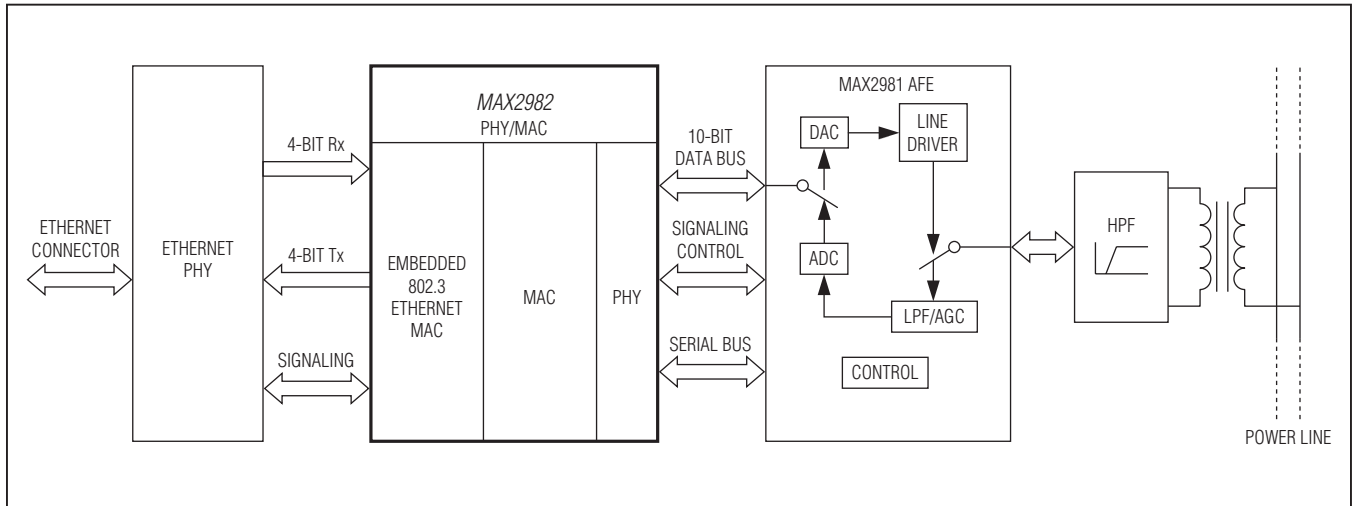

ABRIDGED

MAX2982 Industrial Broadband Powerline Modem

Ordering Information

PART	TEMP RANGE	PIN-PACKAGE
MAX2982GCD+	-40°C to +105°C	128 LQFP
MAX2982GCD/V+	-40°C to +105°C	128 LQFP

+Denotes a lead(Pb)-free/RoHS-compliant package.
/V denotes an automotive-qualified part.

Chip Information

PROCESS: CMOS

Package Information

For the latest package outline information and land patterns (footprints), go to www.maxim-ic.com/packages. Note that a "+", "#", or "-" in the package code indicates RoHS status only. Package drawings may show a different suffix character, but the drawing pertains to the package regardless of RoHS status.

PACKAGE TYPE	PACKAGE CODE	OUTLINE NO.	LAND PATTERN NO.
128 LQFP	C128+1	21-0086	90-0143



Maxim cannot assume responsibility for use of any circuitry other than circuitry entirely embodied in a Maxim product. No circuit patent licenses are implied. Maxim reserves the right to change the circuitry and specifications without notice at any time. The parametric values (min and max limits) shown in the Electrical Characteristics table are guaranteed. Other parametric values quoted in this data sheet are provided for guidance.

Maxim Integrated 160 Rio Robles, San Jose, CA 95134 USA 1-408-601-1000

3